

Front Suspension:

Ride Height: _____
 Camber: _____
 Toe: _____
 Arm Spacing: _____
 Tower Type: _____
 Wheel Hex: _____
 Steering Block KPI: _____
 Caster Block Spacing: _____
 Notes: _____

Upper Arm Insert: 

Steering Bellcrank Position:
 Up
 Down

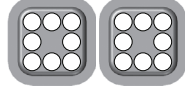
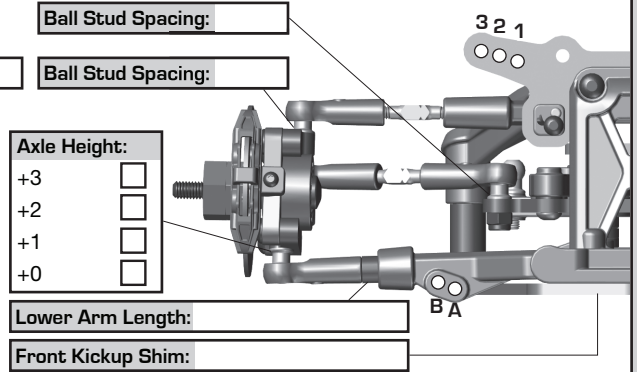
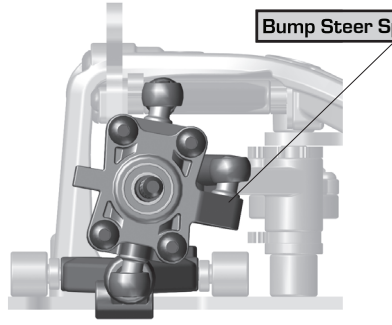
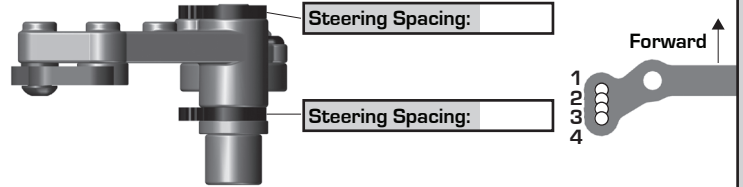

Rear Suspension:

Ride Height: _____
 Camber: _____
 Arm Spacing: _____
 Tower Type: _____
 Wheel Hex: _____
 Hub Spacing: _____
 Notes: _____

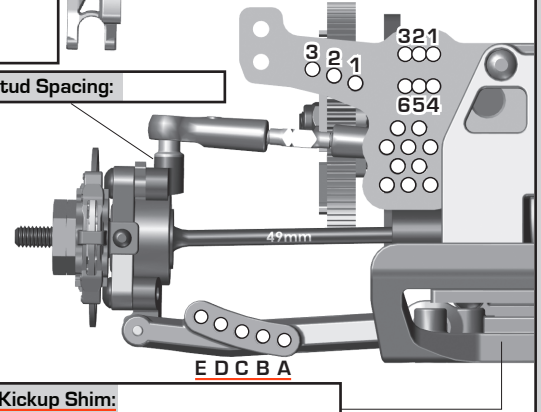
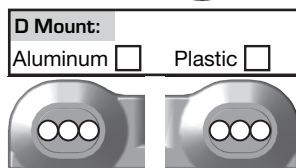
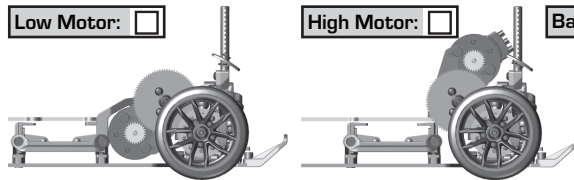
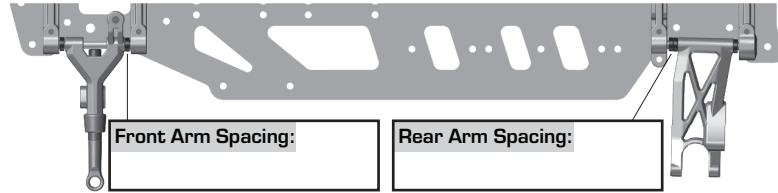

Electronics:

Radio: _____
 Servo: _____
 EPA: Throttle: _____ % Brake: _____ %
 ESC: _____
 ESC Settings: _____
 Motor / Wind: _____ Timing: _____
 Pinion: _____ Spur: _____
 Motor Position: _____
 Battery: _____ Weight: _____
 Battery Position:
 Fwd: Back: High: Low: Other:
 Notes: _____
 Gyro: _____
 Gyro Settings: _____
 Gyro Mode: _____
 Limit Gain: _____
 Notes: _____

Drivetrain:

Differential: _____ Ball Diff:
 Gear Diff: Gear Diff Locked:
 Diff Setting: _____
 Notes: _____

Tires:

Front Tires: _____
 Front Compound: _____
 Rear Tires: _____
 Rear Compound: _____
 Wheel (F/R): _____
 Notes: _____

Body, Chassis, Weight:

Body: _____
 Rear Wing: _____
 Chassis Type: _____
 Chassis Weights: _____
 Total Vehicle Weight: _____

Shocks:

	Front	Rear
Piston:	_____	_____
Thickness:	_____	_____
Fluid:	_____	_____
Spring:	_____	_____
Limiters: Int: _____ Ext: _____ Int: _____ Ext: _____		
Stroke:	_____	_____
Shock Length:	_____	_____
Eyelet Length: 0 <input type="checkbox"/> +3 <input type="checkbox"/> +6 <input type="checkbox"/> 0 <input type="checkbox"/> +3 <input type="checkbox"/> +6 <input type="checkbox"/>		
Alum. Bodies: <input type="checkbox"/> Chrome Shafts: <input type="checkbox"/> Machined Spacers: <input type="checkbox"/>		
Notes: _____		



Stroke

Vehicle Comments:

Notes: _____

